

# Battery Test Systems

## Industrial Testing Approach

- Loading tray to support mass battery connections
- Lever action to connect full tray of battery electrical connections
- PXIe chassis with hot swappable channels
- Texas Instruments Chips for Charge/Discharge

## Technical Features

- High Discharge Currents up to 20A
- Optimized for 18650 and larger cylindrical cells
- Galvanostatic cycling of cells and small modules
- Multiplexed Impedance to each channel

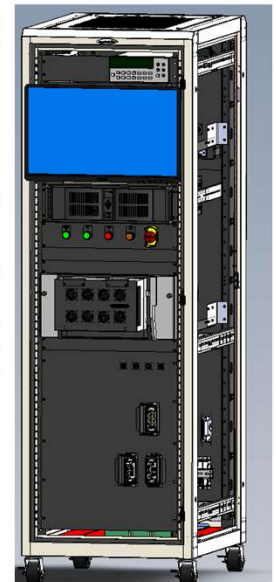
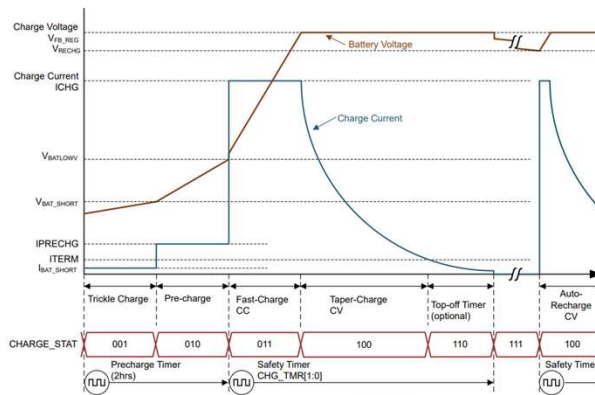
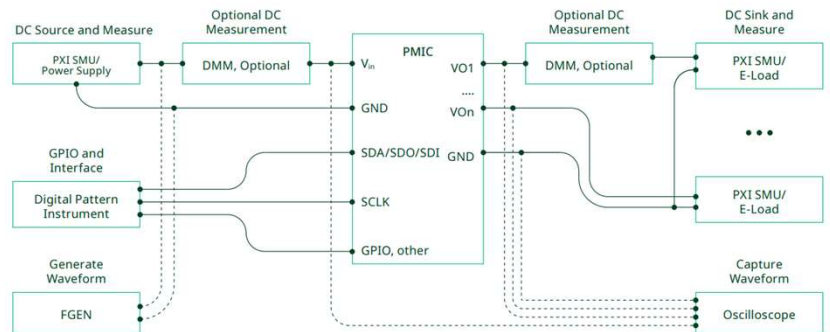

Flexline LLC also provides custom solutions for automation, manufacturing and test. Specializing in unique and challenging requirements, Flexline offers:

- Custom, in-house manufacturing and controls development
- System assembly and controls designs
- Single-system products or single-task machinery for production
- Concept design to working equipment solutions

Call Flexline for all your specialized needs.

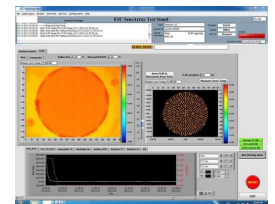

**Flexline LLC**  
 1394 Tully Road, Suite 201  
 San Jose, CA 95122  
 408-295-3901, ext 18  
 sales@flexlinellc.com